



RBG SYSTEM

AEROSOL GENERATOR

For Dust and Powders

Made in Germany

Fast. Simple. Reproducible.

RBG SYSTEM

Low-concentration solid particle aerosols produced from dust and powders are required for many applications in research, development, and quality assurance and for the calibration of particle measurement devices.

A high level of dispersion constancy is required for those substances to the point of lowest dosing rates. Additionally, a good reproducibility during aerosol generation must be guaranteed.



The **RBG SYSTEM** fulfills these requirements for mass flows from 0.04 up to 800 g/h.

A special advantage:

The dosing and dispersion systems are fast and simple adaptable to different application conditions.

This allows for example:

- Use of different powders
- Use of different carrier gases
- Overpressure operation up to 10 bar
- Negative pressure operation down to 600 mbar absolute

Application Examples



FILTER TESTING



**DEVELOPMENT OF NEW FILTER
AND FILTER MATERIAL**



CALIBRATION



PARTICLE IMAGE VELOCIMETRY

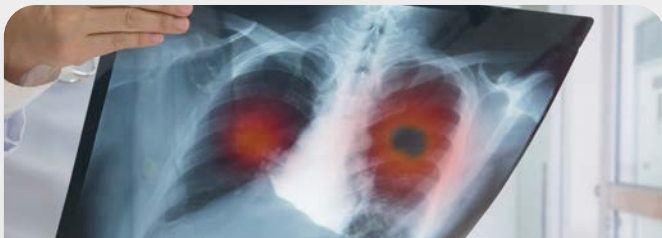

INHALATION TEST



MASK CHECK

Principle of Operation

The **RBG SYSTEM** from Palas is characterized by its precision and easy handling.

The material inside the reservoir is moved upwards at a defined speed by a stepper motor and is collected by the rotating brush which transports the powder into the dispersion head. A high velocity gas stream blows the powder out of the brush and disperses it in the dispersion nozzle. The mass flow can thus be easily and reproducibly determined from the set feed rate and the cross-section of the transport piston, as well as the packing density of the powder.

The dispersion gas flow can be set manually or fully automated with the integrated air flow control. Four different dispersing covers can be used for optimal dispersion.

The **RBG SYSTEM** can be set manually via the display keys or via a connected computer with the Palas control software included in the shipment.

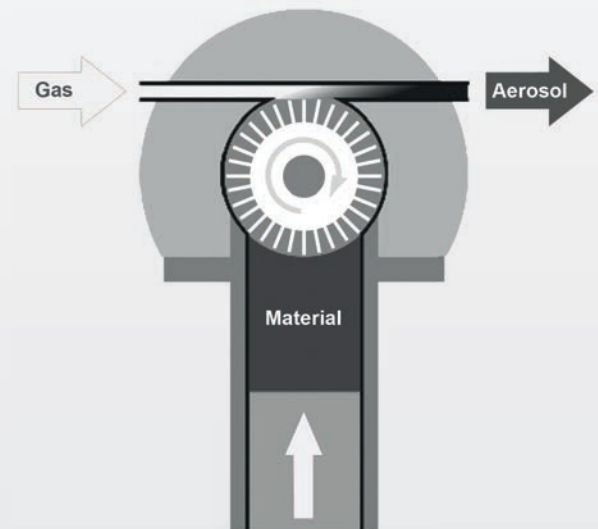

RBG SYSTEM

	RBG PROFESSIONAL	RBG BASIC	RBG SOLO
Feed stock reservoir with up to 110 mm filling height	X	X	X
USB connection for digital remote control	X	X	X
Operation with different carrier gases, e.g., nitrogen	X	X	X
Fast change of the reservoir in approx. 30 s	X	X	X
LCD functional display with keyboard	X	X	X
Robust plastic housing	X	X	X
Electrical supply by wide-range power supply unit (24 V)	X	X	X
Automatic volume air flow control with integrated mass flow meter & valve	X		X
Capsuled maintenance-free motor for dispersion brush, pressure-tight up to 10 bar	X		
Integrated pump for operation without compressed air supply			X

Special Advantages and Benefits

RELIABILITY

- High reproducibility for measurements due to very good long-term dosing consistency
- Ideal for dispersion of many non-cohesive dusts

FLEXIBILITY

- Fast adaptation to changing test conditions with different solids containers and dispersion lids
- Wide application range up to 10 bar over pressure and 0.4 bar negative pressure and with different carrier gases
- Fast response

USER FRIENDLINESS

- Easy to operate due to automatic monitoring of the volume flow and LCD display for all parameters
- Convenient remote control of the **RBG SYSTEM** via supplied Palas software via USB interface

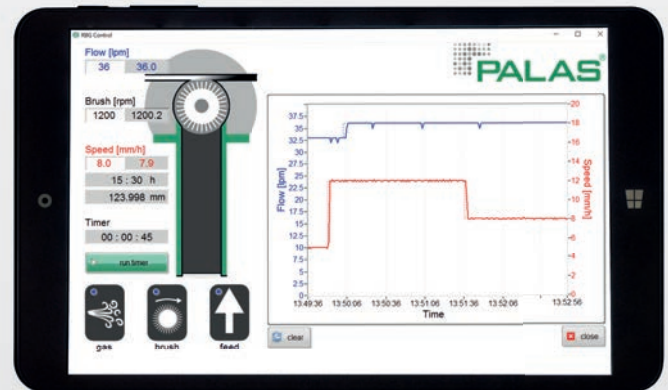

Technical Features

Particle size range	0.1–200 µm
Particle material	Non-cohesive powders and bulks
Max. particle number concentration	Approx. 10^7 particles/cm ³
Volume flow	Depending on the dispersion cover: 8–180 NI/min (RBG PROFESSIONAL) 8–85 NI/min (RBG BASIC) 8–40 NI/min (RBG SOLO)
Mass flow (particles)	0.04–800 g/h (with an assumed compacted density of 1 g/cm ³)
Maximum over pressure	10 barg (RBG PROFESSIONAL) 0.2 barg (RBG BASIC) 0.1 barg (RBG SOLO)
Pre-pressure	4–13 bar (RBG PROFESSIONAL) 4–8 bar (RBG BASIC)
Negative pressure	0.4 bar
Filling quantity	2.7–88 g (with an assumed compacted density of 1 g/cm ³)
Interfaces	USB type B
Dimensions (H • W • D)	515 • 330 • 240 mm
Weight	Approx. 15 kg (RBG PROFESSIONAL, RBG BASIC) Approx. 19 kg (RBG SOLO)



Palas is a leading developer and manufacturer of highprecision instruments for the generation, measurement and characterization of particles in air.

With more than 30 active patents, Palas develops technologically leading and certified fine dust and nanoparticle analyzers, aerosol spectrometers, generators and sensors as well as related systems and software solutions. Palas was founded in 1983 and employs more than 100 people.

Palas GmbH

Siemensallee 84 | Building 7330 | 76187 Karlsruhe

Phone: +49 721 96213-0

www.palas.de